



eClassroom

GCSE Mathematics

Angles

Questions

Pearson Edexcel GCSE & iGCSE Mathematics



Section A — Foundation



Join students already acing their exams.

Book your FREE lesson at www.eclassroom.org.uk



Worked Examples

[Fluency]

Find the value of x .

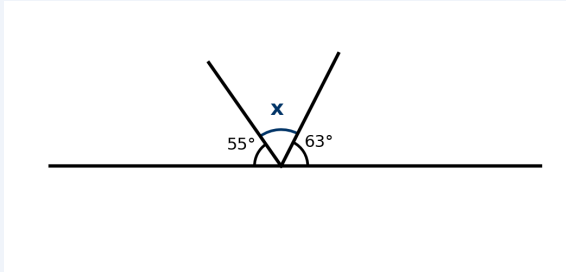

Angles on a straight line sum to 180° : $55 + x + 75 = 180 \rightarrow x = 50^\circ$

[Reasoning]

l_1 and l_2 are parallel. Find angle a .

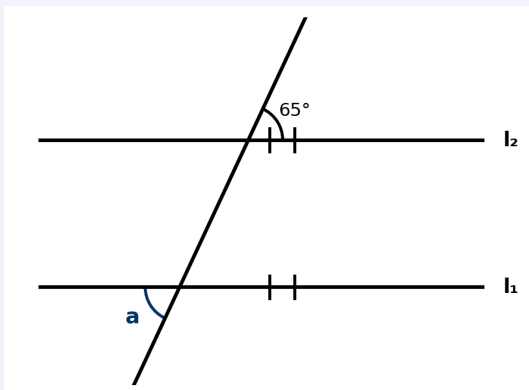

Alternate angles are equal (Z-angles): $a = 65^\circ$

[Problem Solving]

Find the interior angle of a regular hexagon.

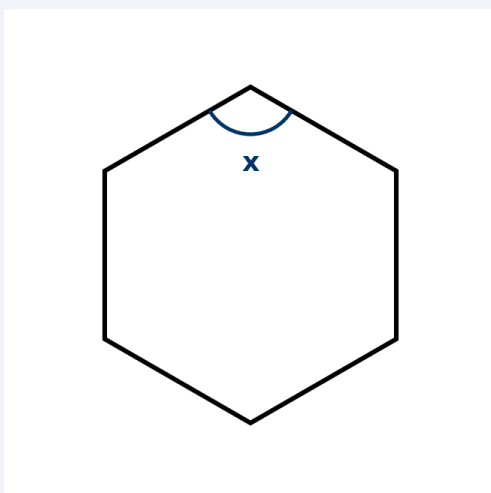

Sum = $(6-2) \times 180 = 720^\circ$. Each = $720 \div 6 = 120^\circ$



[Fluency]

1.

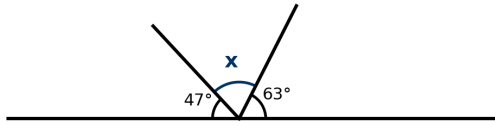

Find the value of x .

(2 marks)

[Fluency]

2. Two straight lines cross at a point. One angle formed is 74° .
Write down the size of the vertically opposite angle. Give a reason.

(1 mark)

[Fluency]

3.

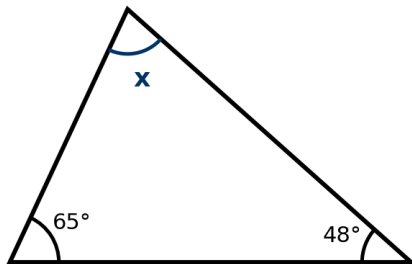

Find the value of x .

(2 marks)



[Fluency]

4.

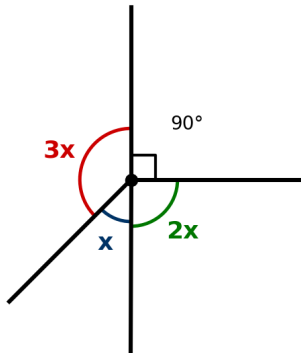

Four angles meet at a point as shown.
Find the value of x .

(3 marks)

[Fluency]

5.

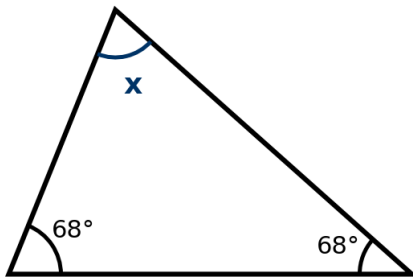

The triangle is isosceles with two equal base angles of 68° .
Find the value of x .

(2 marks)



[Reasoning]

6.

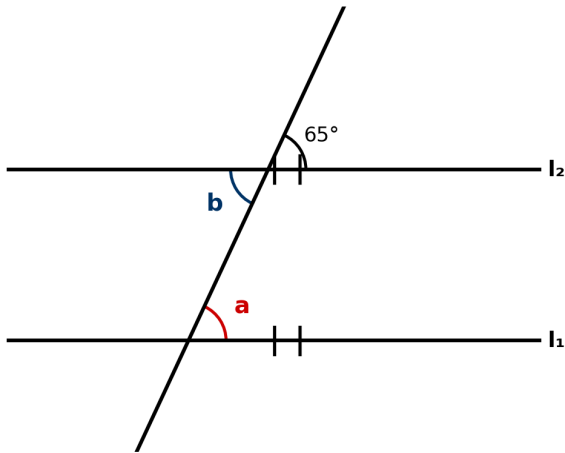

l_1 and l_2 are parallel.

Find the values of a and b , giving reasons for each answer.

(4 marks)

[Reasoning]

7.

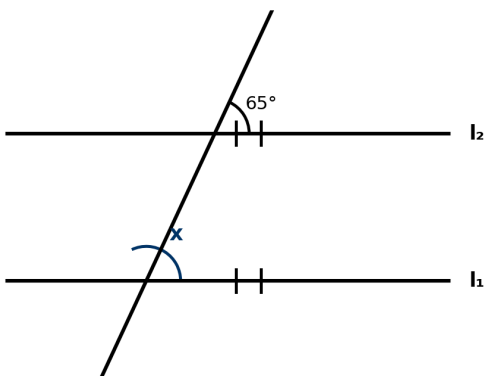

l_1 and l_2 are parallel. Find x . Give a reason.

(2 marks)



[Reasoning]

8.

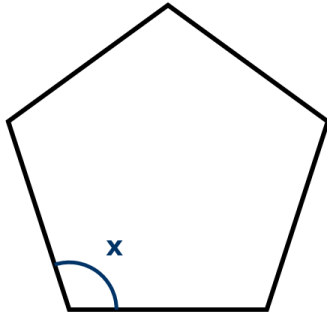

Find the interior angle x of a regular pentagon.
Show your working clearly.

(2 marks)

[Problem Solving]

9. The exterior angle of a regular polygon is 24° .
How many sides does the polygon have?

(2 marks)

[Problem Solving]

10.

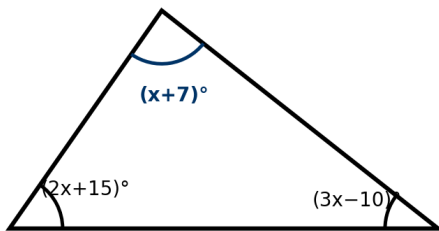

Find the value of x and the size of each angle.

(4 marks)



Section B — Higher



Join students already acing their exams.

Book your FREE lesson at www.eclassroom.org.uk



Worked Examples

[Fluency]

Find the interior angle of a regular 9-sided polygon.

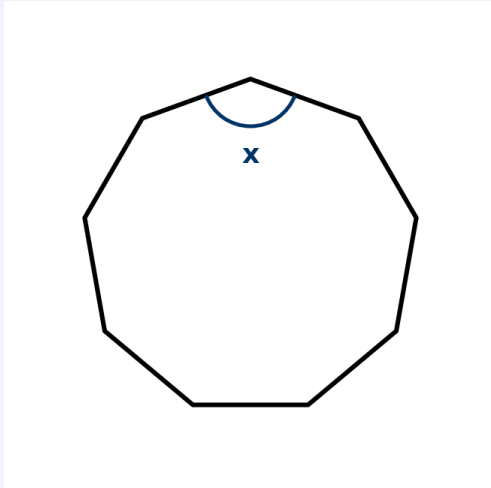

$$\text{Sum} = 7 \times 180 = 1260^\circ. \text{ Each} = 1260 \div 9 = 140^\circ$$

[Reasoning]

Find the bearing of B from A, given that the bearing of A from B is 055° .

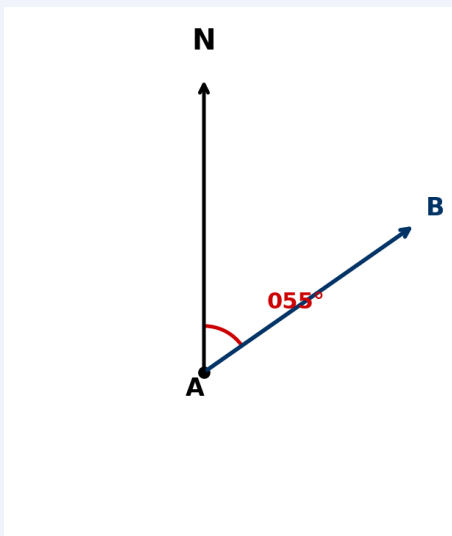

$$\text{Back bearing} = 55 + 180 = 235^\circ$$

[Problem Solving]

Prove that the angles in a triangle sum to 180° .

Draw line PQ through apex C, parallel to AB.

$$\angle PCA = \angle CAB \text{ (alternate, } PQ \parallel AB), \angle QCB = \angle CBA \text{ (alternate, } PQ \parallel AB)$$

$$\angle PCA + \angle ACB + \angle QCB = 180^\circ \text{ (straight line)} \rightarrow \angle A + \angle B + \angle C = 180^\circ \checkmark$$



[Fluency]

1. A ship sails on a bearing of 035° from A to B.
What is the bearing of A from B?

(2 marks)

[Fluency]

2.

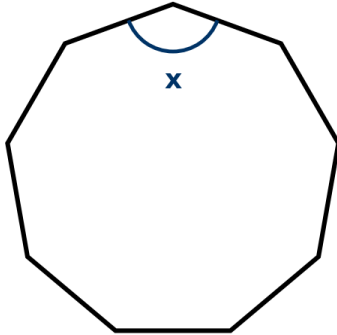

Find the interior angle of a regular 9-sided polygon.

(2 marks)

[Fluency]

3.

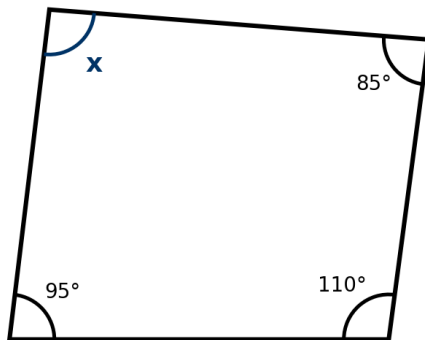

Find the value of x.

(2 marks)



[Reasoning]

4.

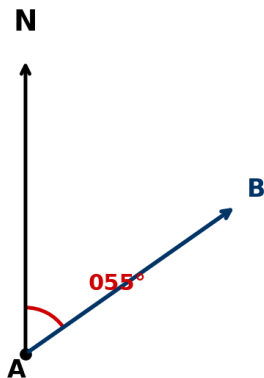

A ship sails from A on a bearing of 055° for 20 km.
Find how far north and how far east of A the ship is.
Give your answers to 1 decimal place.

(4 marks)

[Reasoning]

5.

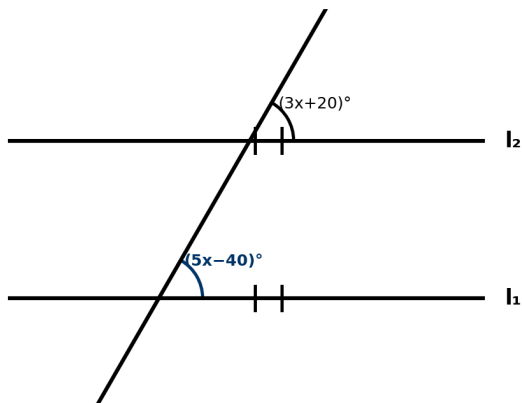

l_1 and l_2 are parallel.
Find x and the value of each angle.

(3 marks)

[Reasoning]

6. A regular polygon has an interior angle of 156° .
How many sides does the polygon have? Show all working.

(3 marks)

[Problem Solving]

7. The angles of a quadrilateral are in the ratio 2:3:4:6.
Find the size of each angle.

(3 marks)

**[Problem Solving]**

8. A pentagon has four angles of 105° , 118° , 92° and 130° .
Find the fifth angle.

(2 marks)

[Problem Solving]

9.

Prove that the exterior angle of a triangle equals the sum of the two non-adjacent interior angles.

(3 marks)

[Problem Solving]

10.

Two regular polygons share a common edge. One is a regular hexagon and one is a square.
Show that an equilateral triangle can fill the remaining gap to tessellate around the shared vertex.

(4 marks)